

The numbers shown in the circles below are sticker numbers. Circled numbers in parentheses indicate the sticker goes on the opposite side. The numbers in the rectangles are instruction steps.

STICKER PLACEMENT

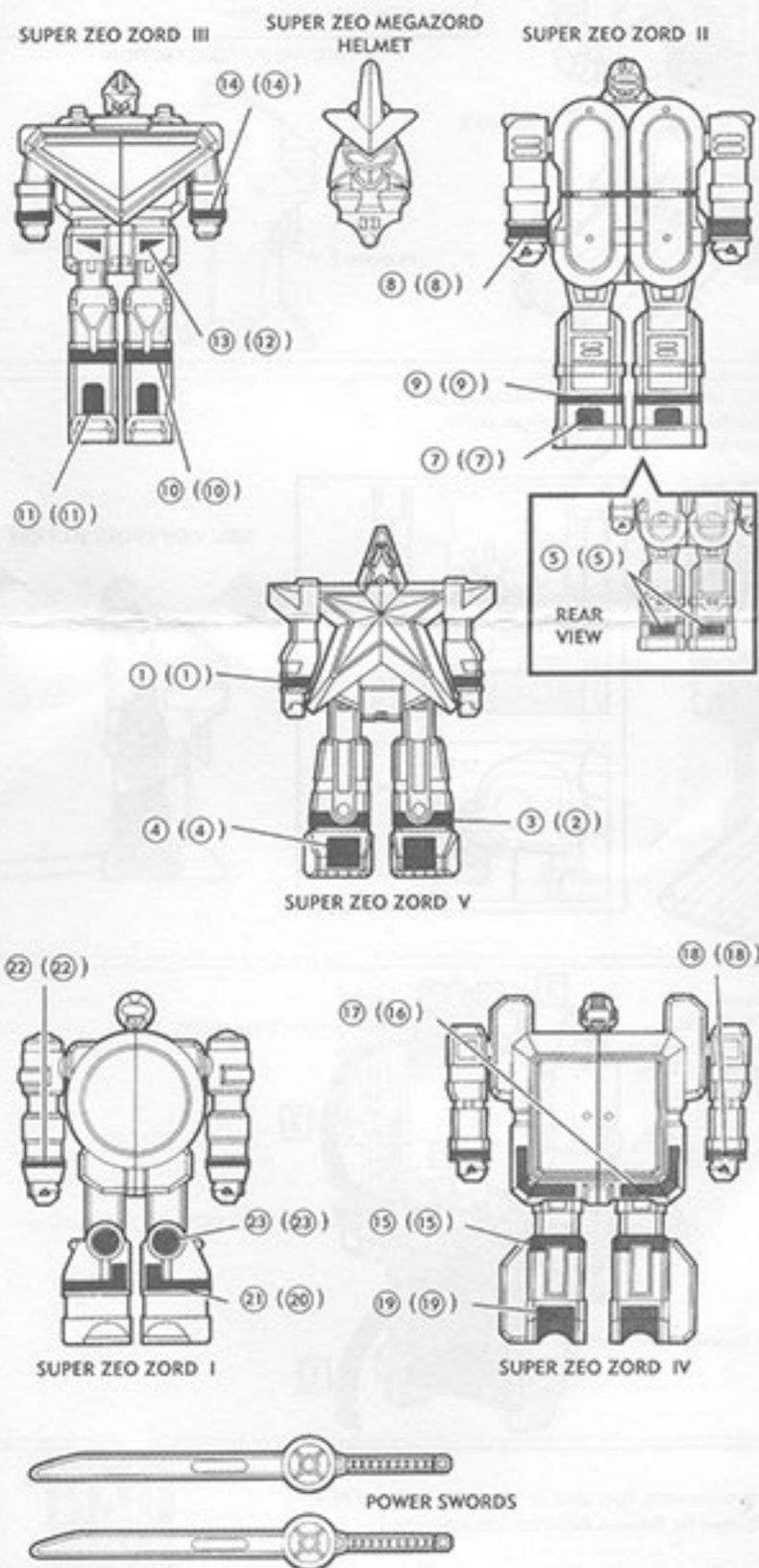

HOW TO MORPH THE SUPER ZEO ZORDS

MORPHING SUPER ZEO ZORD V

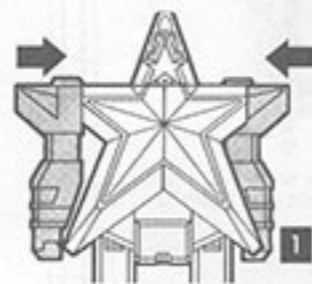

1 Press both shoulders snugly into the body.



2 Rotate both legs back and up, until they snap in place.



Make sure the slots on the legs snap over the tabs on the back.



3 Rotate the head around to line up the top of the red star.

MORPHING SUPER ZEO ZORD II

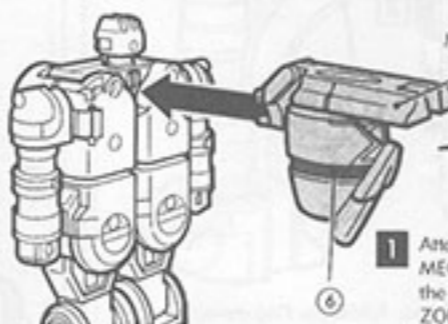

1 Attach the SUPER ZEO MEGAZORD Helmet to the back of SUPER ZEO ZORD II by snapping the tabs and slots together.

SUPER ZEO MEGAZORD Helmet



Helmet Ornament
The Helmet Ornament can move up and down.

Hand Release Lever

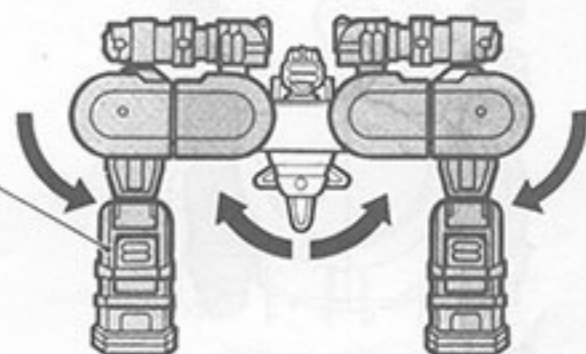

2 Separate the body and rotate the two halves up and out. Then, rotate the legs down, as shown.

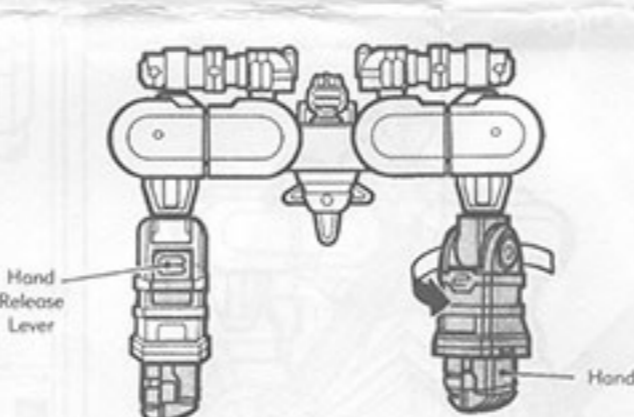

3 Press the Hand Release Levers and the Hands will pop out from the bottoms of SUPER ZEO ZORD II's feet. Then, rotate the legs 180°, so the thumbs on the hands face inward.

Hand Release Lever

Hand

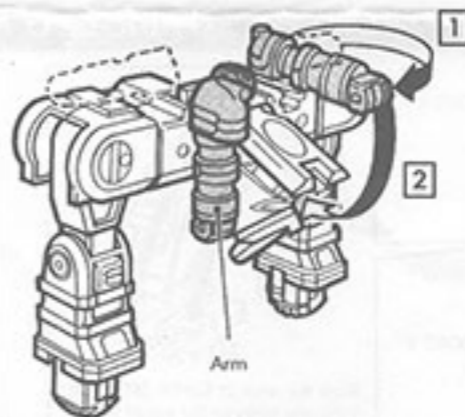

4 First, rotate the arms around toward the rear. Then, rotate them down at the shoulder joints, until the hands point straight down.

Arm

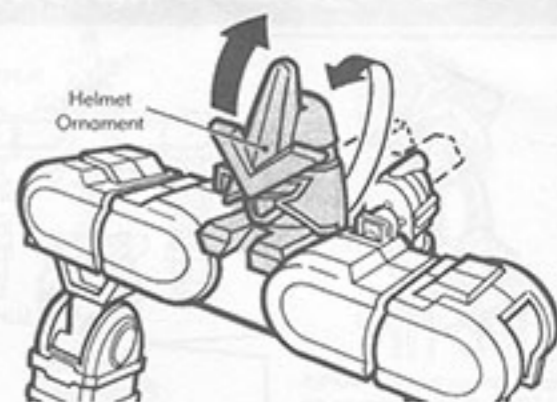

5 Rotate the SUPER ZEO MEGAZORD Helmet up and over SUPER ZEO ZORD II's head. Then, move the Helmet Ornament up above the eyes.

Helmet Ornament

MORPHING SUPER ZEO ZORD III



1 Rotate both arms all the way around to the back of SUPER ZEO ZORD III.

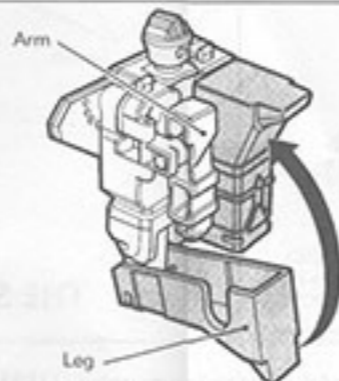

2 Rotate the Legs back and around, until they snap into place over the Arms.

Leg

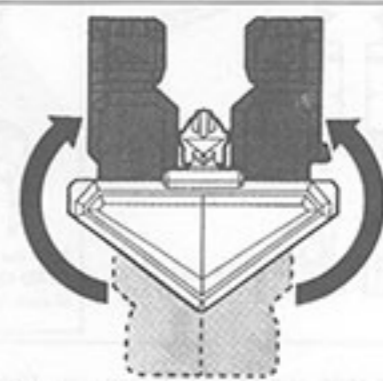

3 Separate the body at the bottom, and rotate each half up and over the head, as shown.



4 Rotate the head back and down, as shown.

HOW TO MORPH THE SUPER ZEO ZORDS

MORPHING SUPER ZEO ZORD IV

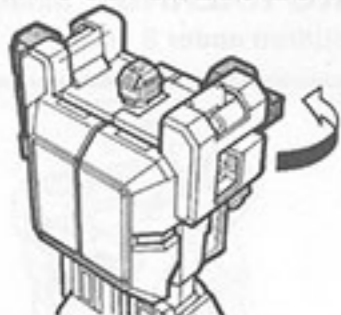

- 1 Rotate both arms all the way around to the back of SUPER ZEO ZORD IV.

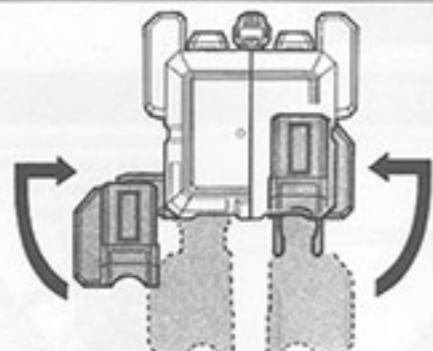

- 2 Rotate both legs up and around at the hip and knee joints and snap them into the sides.

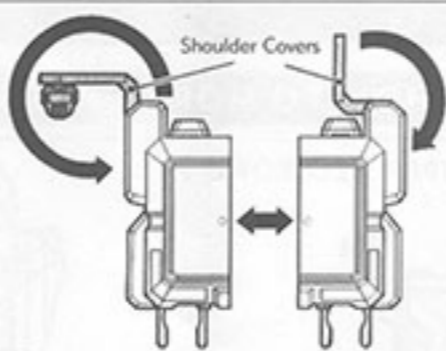

- 3 Split the body in half, and rotate the two shoulder covers out and around to the sides of SUPER ZEO ZORD IV.

MORPHING SUPER ZEO ZORD I

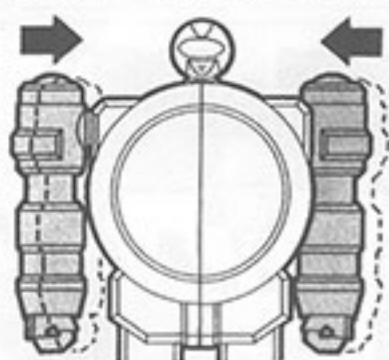

- 1 Push both arms into the sides by pressing the shoulders in.

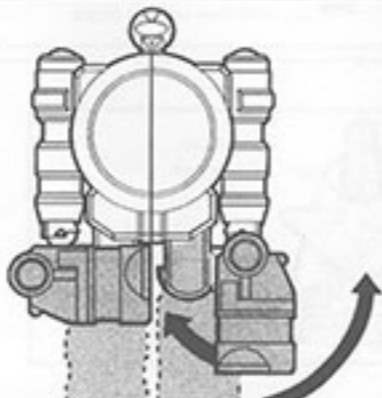

- 2 Rotate both legs out, then rotate the feet around and in toward the center of the body, as shown.

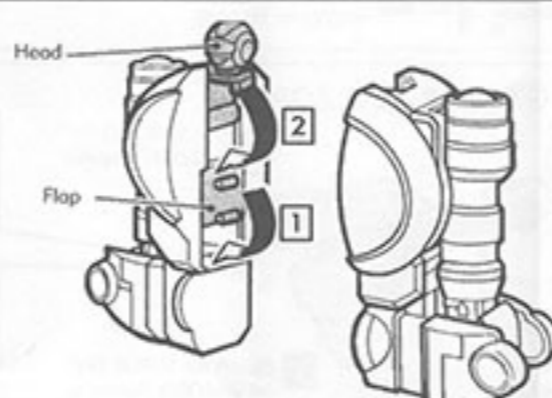

- 3 Split the body into halves. Rotate the Flap down, then rotate the Head down, as shown by the two arrows.

HOW TO ASSEMBLE THE SUPER ZEO MEGAZORD



Snap the tabs on the top of SUPER ZEO ZORD III into the slots on the bottom of SUPER ZEO ZORD V.

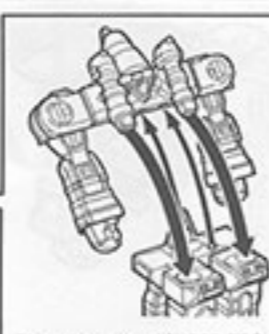
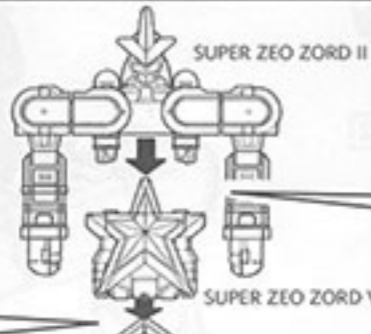

Place the arms of SUPER ZEO ZORD II into the holes on the top of SUPER ZEO ZORD V, and snap the two zords together.

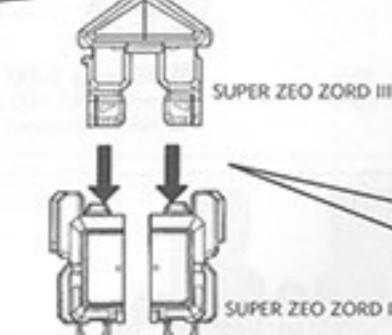

Snap the U hooks on the bottoms of SUPER ZEO ZORD IV over the arms of each half of SUPER ZEO ZORD I.



Snap the bottoms of SUPER ZEO ZORD III into the holes on the tops of each half of SUPER ZEO ZORD IV.

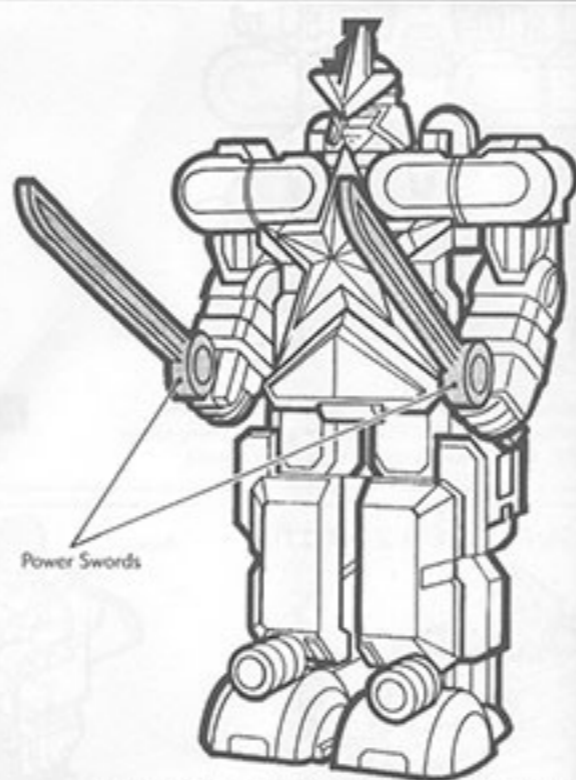

THE SUPER ZEO MEGAZORD

USING THE SUPER ZEO MEGAZORD WITH PYRAMIDAS

- 1 Remove Platform 3, as described in the inset on the right, then fold Platform 2 up. Make sure that Platform 1 is in the position shown below.

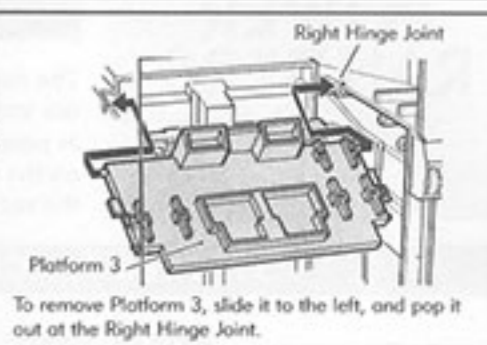
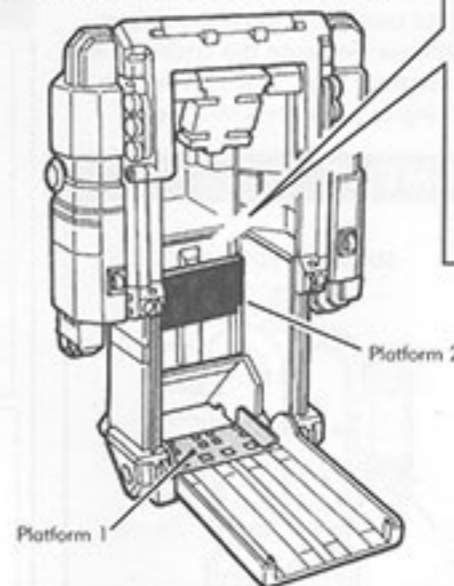

To remove Platform 3, slide it to the left, and pop it out at the Right Hinge Joint.

SIDE VIEW CROSS SECTION

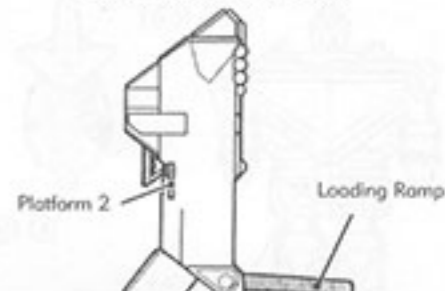

- 2 Place the SUPER ZEO MEGAZORD inside PYRAMIDAS so the edges of his shoulders rest on the outer edges of the Side Panels, as shown in the insets below.

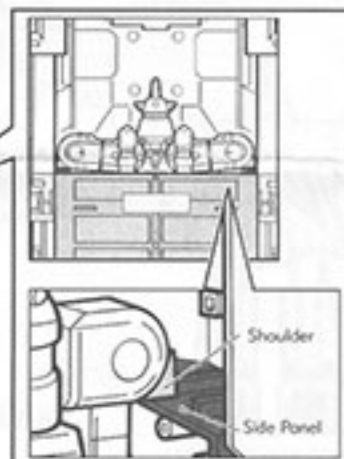
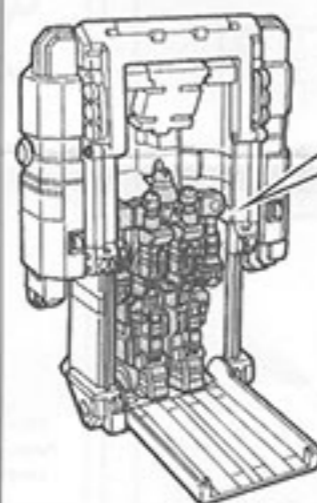

SIDE VIEW CROSS SECTION

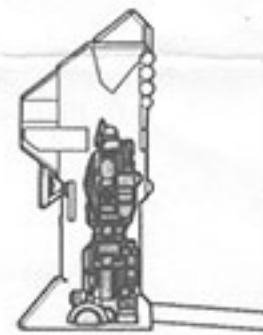

- 3 Close the Loading Ramp, and rotate the RED BATTLEZORD Platform back and down, as shown in the diagram to the right. Then, rotate PYRAMIDAS' Head up.

