



# RESCUE BLASTER™



Asst. #4435 / Item #4436

**WARNING:**  
**CHOKING HAZARD - Small parts.**  
**Not for Children under 3 years.**

**CAUTION: PLEASE READ BEFORE PLAYING WITH TOY**

- **Do not:** 1) aim toy at anyone, 2) hit anyone with toy, 3) poke anyone with toy, 4) swing toy at anyone.
- **Be careful** not to pinch fingers with hinged parts of toy.

**Requires 2 AAA batteries. Batteries not included.**

**CAUTION:** Keep batteries away from children. Batteries may be harmful if swallowed. **NOTE:** Make sure you use two new batteries. Do not mix old and new batteries. Do not mix alkaline, standard (carbon-zinc) or rechargeable (nickel-cadmium) batteries.

## CONTENTS

Main body	1	Holster	1	Sticker set	1
Grip	1	Badge	1	(Circled numbers show sticker placement.)	

## HOW TO INSERT BATTERIES

1. Using a small screwdriver, turn screw counterclockwise until loose, then remove battery cover.
2. Insert two AAA batteries, making sure to line up "+" and "-" indicators, as shown.
3. Replace battery cover. Insert screw into hole and turn clockwise until secure.

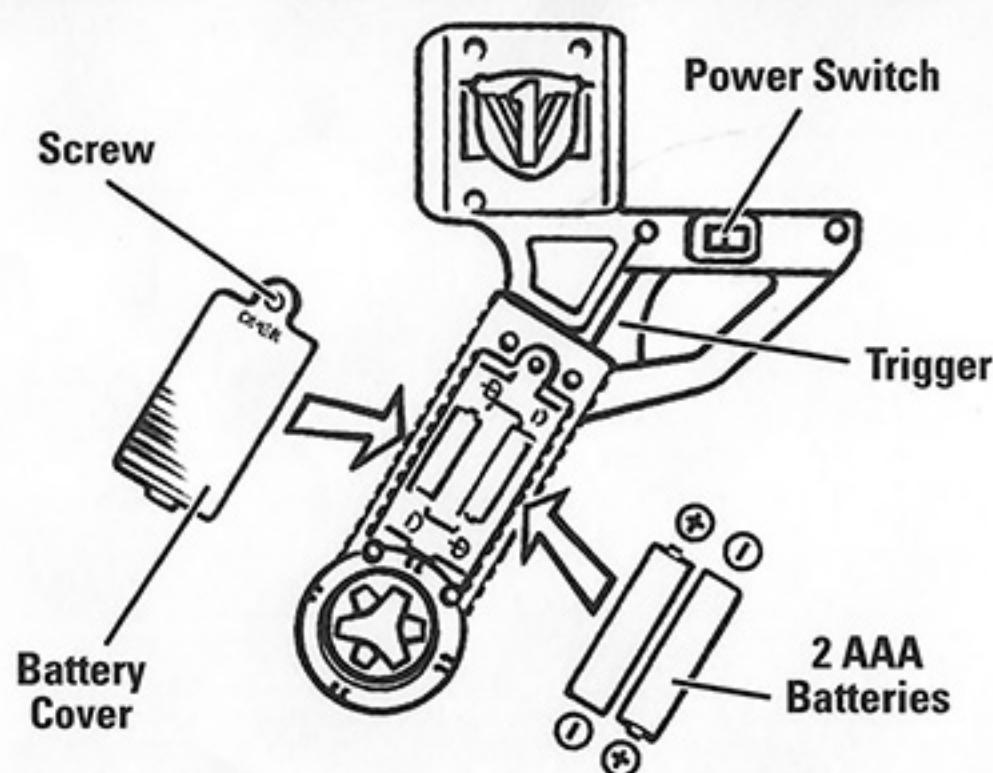

## HOW TO TRANSFORM INTO BATTLE MODE

1. Insert the main body into the grip **orange end first**, as shown in figure C.
2. Rotate the body away from you until it locks into place with the hook on top, as shown in figure D. (Circled numbers show sticker placement.)
3. Rotate the grip upwards until it clicks into place, as shown in figure E. Extend the sword to complete. Lock sword into place by sliding red button. Squeeze the trigger to activate lights and sound.

Figure C

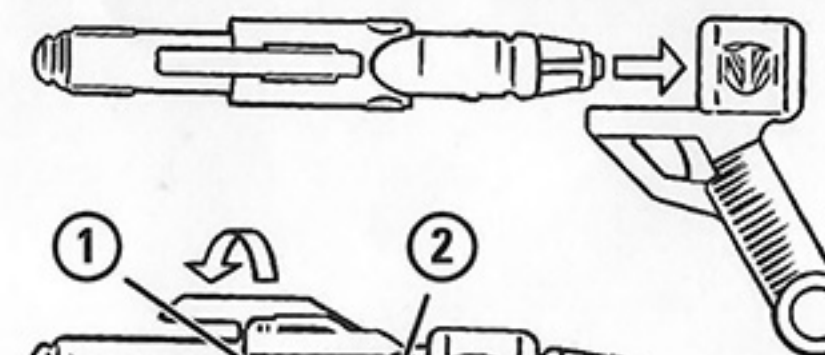

Figure D

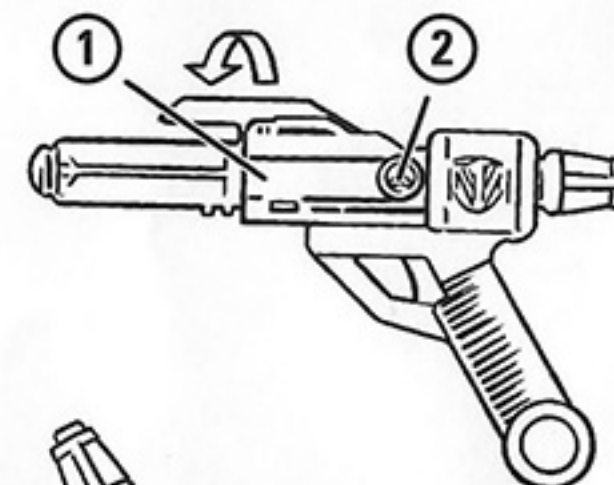
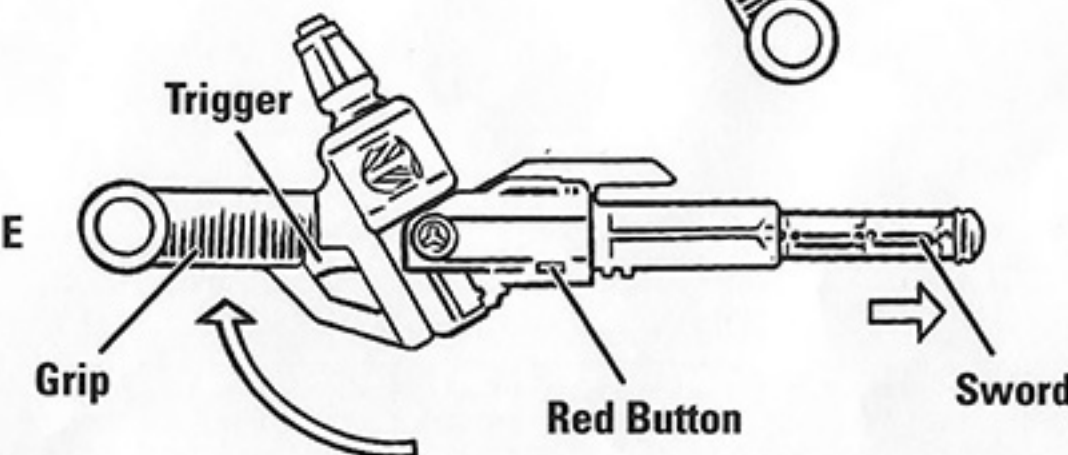
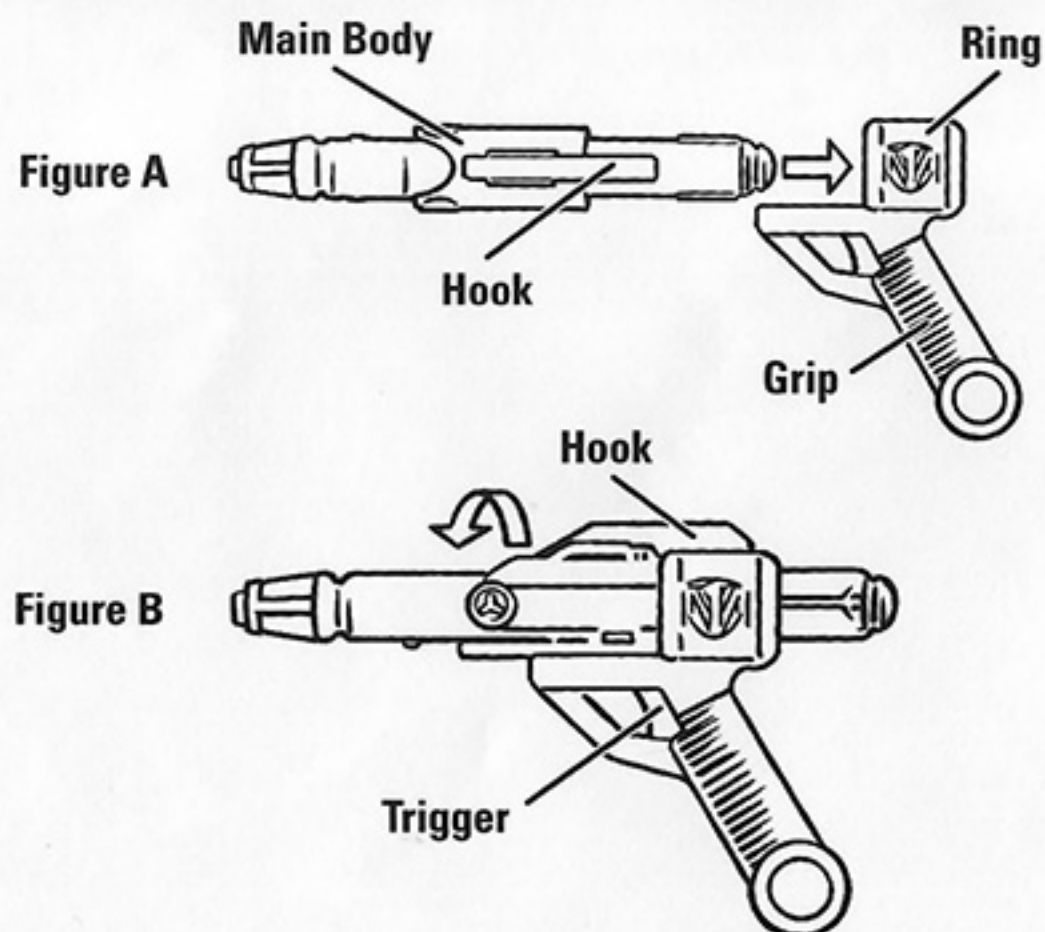

Figure E



## HOW TO TRANSFORM INTO WEAPON MODE

1. Insert the main body of the weapon through the ring in the grip. Make sure the hook is facing you, as shown in figure A.
2. Rotate the body away from you until it locks into place with the hook on top, as shown in figure B.
3. Squeeze the trigger to activate lights and sound.



## HOW TO USE HOLSTER

1. Attach the holster to your belt to carry the Rescue Blaster.

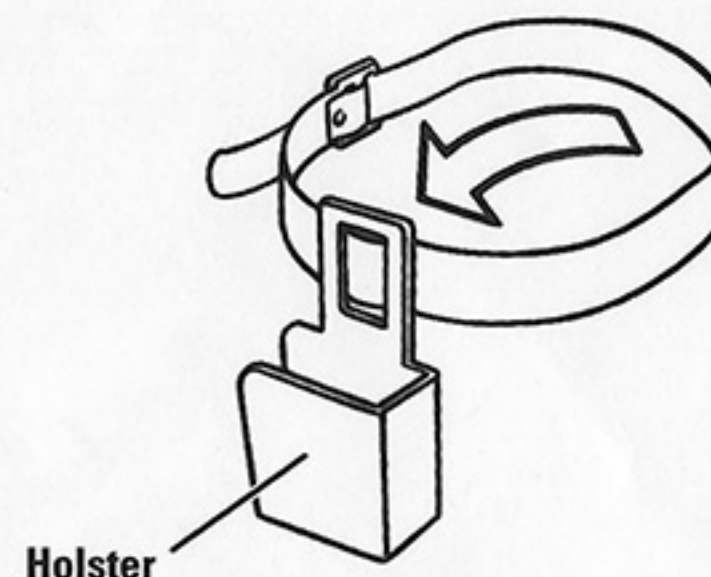

## HOW TO PLACE BADGE

1. Attach the badge to your pocket as shown.

